

Additional Operation & Maintenance Information For Model LD100AB Loop Drive Winch-Hoist Part # 745030

Capacity: 20,000 Lb Rolling Load; 800 Lb. Line Pull

This parts list is to be used in conjunction with the 100AB Operation and Maintenance guide. See "Installation Tips" for more information on installing and rigging the LD100AB. To insure that you receive the proper parts, we must have the model and serial number of the winch and the part numbers of the parts you need.

The LD100AB differs from the standard 100AB in the following ways:

- * The LD100AB is designed to be used with a continuous loop of 1/4" wire rope.
- * The LD100AB is designed to move rolling loads forward and reverse.
- * The LD100AB is not designed for lifting loads or pulling loads on an incline.

Installation Tips:

In addition to the recommendations from the 100AB Operation & Maintenance Guide, the LD100AB installation differs in the following ways:

Install the winch so the wire rope is perpendicular to the cable drums.
Align the winch with the load travel so the wire rope cannot escape the drum grooves.
Align the winch with the load so the loaded segment of rope is on the inboard end of the drum.
For proper wire rope spooling, the load should be mounted on a track or trolley.
The grooved cable drums of the LD100A are to be used with 1/4" diameter wire rope only.
Do not allow the rope returning to the drum to interfere with the load.
Do not place any guide sheaves or rollers within 8' of the cable drums.
To install the wire rope:

- Place the load near the winch
- Secure the wire rope to the end of the load opposite the winch.
- Pass the rope through the return pulley(s). Avoid excessive slack
- Bring the rope back to the winch and wrap it around the drum as shown below.
- Use the minimum number of wraps necessary to move the load.
- Run the winch briefly to pull any remaining slack out of the rope.
- Secure the wire rope to the end of the load nearest the winch.
- A load rated turnbuckle may be used between the end of the rope and the load to provide sufficient line tension and take up rope stretch..

Important: Use the minimum amount of tension necessary to move the load.

Test the entire assembly and make any necessary adjustments.

Typical Installation

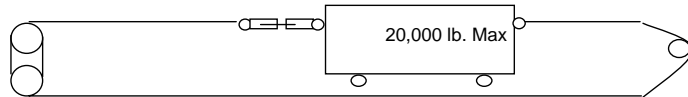

Rigging Illustration

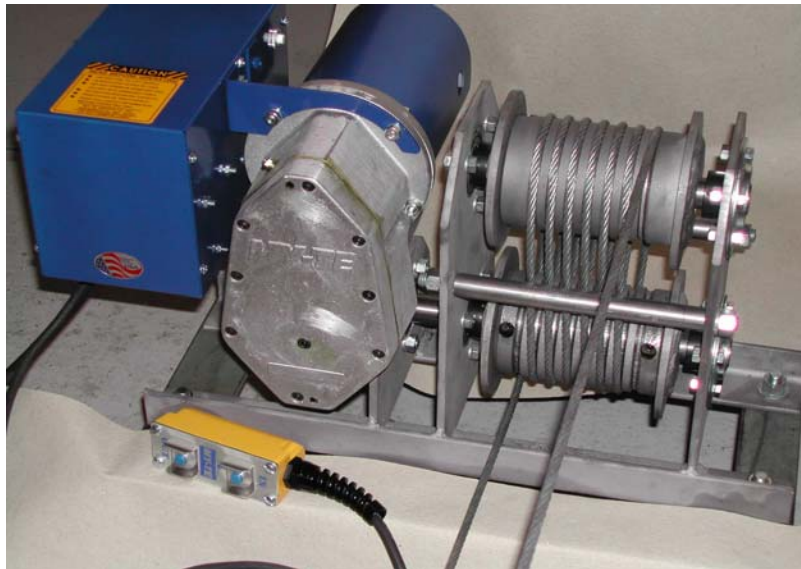

Consult the factory or your nearest My-te Dealer with any questions.

Minimum Order \$20.00

My-te Products, Inc.
9880 E. 30th St.
Indianapolis, IN 46229
800-840-9880 - Ph
317-897-9880 - Fax
www.myte.com
sales@myte.com

Model 100AB

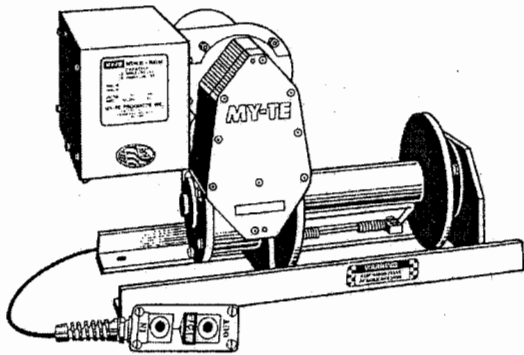

**2000# Double
Line Lift Capacity**

MY-TE Winch and Hoist **OPERATION and MAINTENANCE**

OF
All 115 Volt AC Winches
Main Parts List for 100AB, 150AB
Used with Supplement Parts List for 800B

READ THIS BEFORE OPERATING UNIT

INSTALLATION:

Mount on clean, flat surface. Bolt down with 6-1/2" bolts. For ease of service, we do not recommend welding frame to surface.

Unit should be plugged into a 115 Volt A.C. grounded receptacle. Use of extension cords may cause power loss at full capacity. Make sure the voltage and type of current stamped on the name plate is used. The 115 Volt units require 19 amps. service for maximum lift, and uses a manual reset circuit breaker rated at 20 amps.

For additional safety, a power disconnect may be installed to provide a means of cutting power in place of using the power cord to disconnect.

Before the unit is wall mounted, or mounted upside down, remove P/N 286260 Oil Plug Valve and exchange with P/N 286250 Oil Plug located below the control box on the worm gear housing cover.

CABLE CONNECTION AND CABLE SAFETY:

Maintain at least 4 wraps of cable on the drum at the maximum reach. The drum cable clamp is not designed to hold load. Inspect the winch, sheaves and cable frequently. Especially watch for frayed cable, loose parts and worn components which may be hazardous. Use the correct size and length of cable for the job. We recommend use of 1/4" cable for most jobs up to 2000 lb. double line. Always provide a 5 to 1 safety factor.

The cable tensioner is designed to prevent the cable from riding over the drum flanges and to maintain a constant pressure against the cable to keep it from binding.

When installing the cable, cable should be placed between the drum and the tensioner, bringing cable around drum to hold in flange. Push cable through hole and secure screws so that they do not extend through the drum flange and interfere with cable tensioner. Be sure cable is wrapped as evenly as possible on drum.

For best results, use only enough cable to meet specific job requirements.

Worn cable is dangerous. Replace cable that has become frayed, broken, kinked or abraded.

OPERATION:

These units are designed for intermittent duty operation. Mfg. recommends a 25% duty cycle. That is, for good motor life, usage of 15 minutes out of one hour is preferable.

To prevent shock loading, slowly remove slack from cable before full load is moved.

The remote control switch is a special 4 wire control which is part of the dynamic brake control system. Changing the switch to some other type will eliminate the braking action. Use only factory provided switch.

Remote switch provides forward and reverse control through a 24 volt transformer. Lifting power is the same in either direction.

**MY-TE WINCH-HOISTS ARE DESIGNED
FOR MATERIAL HANDLING USAGE.**

MAINTENANCE:

Check all sheaves, rollers and areas of friction. Be sure they turn freely. Misalignment of cable, dragging sheaves, or rollers will consume a great amount of power.

If the unit is installed outside, be sure to provide a cover to protect motor and controls from the weather. When the unit is in operation be sure cover is completely removed.

Periodic inspection of switch and power cord should be made to detect any damage or cuts which would require replacement.

The gearbox oil is shared between the spur and worm gear housings. The factory-installed oil is a Shell product; Omala 68. It is an EP type industrial gear oil, ISO Grade 68. If this is not available, an SAE 20 weight, non-detergent motor oil is acceptable. Standard capacity is 18 ounces.

TROUBLE SHOOTING AND REMEDIES:

CAUTION: BEFORE SERVICING OR INSPECTING UNIT FOR PROBLEMS BE SURE TO DISCONNECT POWER.

If the unit does not run, check power supply. Be sure correct voltage and frequency are being used. Remove power plug and remove control box cover. Visually inspect for loose wires, stuck contacts on relays, and screws which may have worked loose.

If the unit runs but braking is not instantaneous, check resistors and motor brush condition. Bad resistors will affect the dynamic braking. Check resistors for cracked porcelain and exposed wire. Replace as needed. To check resistors electrically, test individually with a continuity test. On ohmmeter, each resistor should have a value of 4 ohms and together a resistance of 2 ohms.

Care should be taken to keep the armature in good condition which may be accomplished by lightly rubbing commutator with a rubstone.

Check brushes to see that they seat on the commutator and are not cracked or badly worn. Replace as needed. Brush springs should provide enough tension to keep brushes seated.

If the unit does not operate properly after the above remedies, contact a qualified electrician or the factory.

WARRANTY:

All My-te winch-hoists are designed for material handling use only. My-te Products, Inc. warrants each My-te winch-hoist to be free of defects in material and workmanship for a period of one year. This warranty does not cover abuse, neglect or use above or beyond rated capacity and duty cycle. Warranty coverage includes shipping charges, one way, by standard ground service. Warranty does not cover cost of installation or removal of winch-hoist from service or loss due to downtime or time out of service. My-te will not reimburse unauthorized warranty expense. The final responsibility for fit of winch-hoist with application rests with end user. The warranty is void if the winch-hoist is altered or parts substituted. This warranty is limited to repair or replacement at manufacturer's factory or a point designated by the manufacturer. Inspection by the manufacturer will determine manufacturer's liability.

My-te Products, Inc.

9880 East 30th St., Indianapolis, IN 46229

317-897-9880

317-897-9811 (fax)

www.myte.com

sales@myte.com (E-mail)

LD100AB Parts List

COMMON FASTENERS AND OTHER ITEMS NOT SHOWN HERE ARE AVAILABLE THROUGH MY-TE PARTS DEPT OR YOUR MY-TE DEALER.

ITEM	QTY	PART No.	DESCRIPTION
1	1	052551	Main Shaft, LD100AB For New WGH Cover
2	1	052560	Drum Shaft, LD100AB Top Drum
3	1	066260	Drum Assy, LD100AB Drive Drum - 8 Grv
4	1	066270	Drum Assy, LD100AB Top Drum - 7 Grv
5	1	081510	Cap, Worm Gear Hsg
6	1	082011	Cover, WGH Closed
7	1	082191	Cover, Brake Motor
8	1	088090	Housing, Worm Gear w/Studs
9	1	088160	Cover, Spur Gear Hsg/Brig
10	1	088170	Housing, Spur Gear/Brig
11	1	112010	Spur Gear
12	1	118040	Idler Gear Assy/Shaft
13	1	118110	Pinion Assy/SS
14	1	118160	Worm Gear, Bronze - No Clutch/SS
15	1	118170	Worm Assy/Shaft, Spacer, Pin, Gear, Keys
16	1	148540	Frame Assy, LD100AB
17	1	171280	Spacer, Thick - Main Shaft
18	1	171310	Spacer, Thin - Main Shaft
19	2	171530	Spacer, Frame
20	1	182032	Brace, Control Box
21	2	211010	Bearing, Main Shaft
22	2	211060	Needle Bearing

ITEM	QTY	PART No.	DESCRIPTION
23	2	212010	Thrust Washer
24	4	218010	Bearing Assy, Flangette
25	1	218020	Bearing Assy, Worm Shaft
26	1	241010	Oil Seal, Main Shaft, Std - 1x2
27	1	241020	Oil Seal, Motor Shaft
28	1	241510	Gasket, Worm Gear Hsg
29	1	241521	Gasket, Spur Gear Hsg
30	2	241530	Gasket, Worm Hsg Cap 1/32
31	2	241540	Gasket, Worm Hsg Cap .010
		248022	Seal & Gasket Kit - Closed WGH Cover
32	4	283020	Screw, 5/16-18 x 1 SHCS
33	8	283080	Screw, 1/4-20 x 1 1/4 SHCS
34	2	285580	Threaded Rod, 1/2-13 x 9 3/8" - LD100AB
35	3	285750	Stud, WGH 3/8-16 x 1-1/4 Zinc
36	2	286250	Oil Plug, 1/8 NPT Hex Head Socket Head
37	1	286260	Oil Plug, Valved 1/8 NPT
38	8	287041	Lockwasher, Split 1/4 High Collar Zinc
39	2	321520	Snap Ring, Worm Shaft - 3/4"
40	1	321530	Snap Ring, WGH - 2"
41	2	351020	Woodruff Key, Worm Shaft
42	5	351030	Woodruff Key, Main Shaft #1008 - 5/16 X 1
43	1	351050	Woodruff Key, Pinion #405

ITEM	QTY	PART No.	DESCRIPTION
44	1	448120	Brake Motor Assy, 115V Hardware
44a	1	443020	Brush Cap, Current Apps
44b	2	443030	Rectifier Assy, Current Apps
44c	1	443040	Motor Brake, Current Apps
44d	1	448130	Brush Set, Current Apps
**		518521	Complete Control Box with Switch & Power Cord
45	1	512020	Panel, Plain - Painted
46	1	512061	Panel, Relay / Brace - Painted
47	1	518010	Control Box Assy, Cover & Bracket -100A
48	1	518261	Panel Assy, Components -115V Hardware
49	1	538033	Hand Switch Assy, 4 Wire / 10 feet Cord -100A
49a	1	241550	Gasket, Switch Housing - 1/16 EPDM
49b	4	281820	Screw, Switch Housing - #8-32 X 1/2 Thread Cutting
49c	2	531140	Switch, Push Button SPDT
49d	1	531521	Switch Housing, Machine & Coated
49e	1	532021	Switch Plate/Switch & Guard
49f	2	532550	Guard, Pushbutton - 5/8 hole
49g	11.4	541020	Switch Cord -18/4 SJO
49h	1	552110	Strain Relief, Switch Housing
50	1	541040	Power Cord Assy, 14/3 with Plug - 15 feet

ITEM	QTY	PART No.	DESCRIPTION
51	1	552020	Strain Relief, Motor Wires
52	2	552040	Strain Relief, 4 Wire Switch Power Cord
53	1	561030	Relay, Power DPDT 24VAC Coil / Aux. Control Switch
54	1	561031	Relay, Power DPDT 24VAC Coil w/o Aux. Control Switch
55	1	562011	Transformer, Terminal Block 115/24 VAC
56	1	562530	Circuit Breaker, 20amp - 115V
57	1	568040	Resistor Assy, 40hm / Mounting Bracket
58	1	568050	Capacitor Assy, 100A, 115V
	1	621020	Decal-Oil Level
	1	621130	Decal-Circuit Breaker
	1	621250	Decal-Drum Warning
	1	621260	Decal-Safety 3 x 3
	1	621270	Decal-Capacity & SN
	1	621290	Decal-Made in America
	1	621310	Decal-Danger Hot!
	.125 GAL.	641530	Oil, Winch-Hoist - Omala #68



LD100AB Parts Drawing

P/N 745030

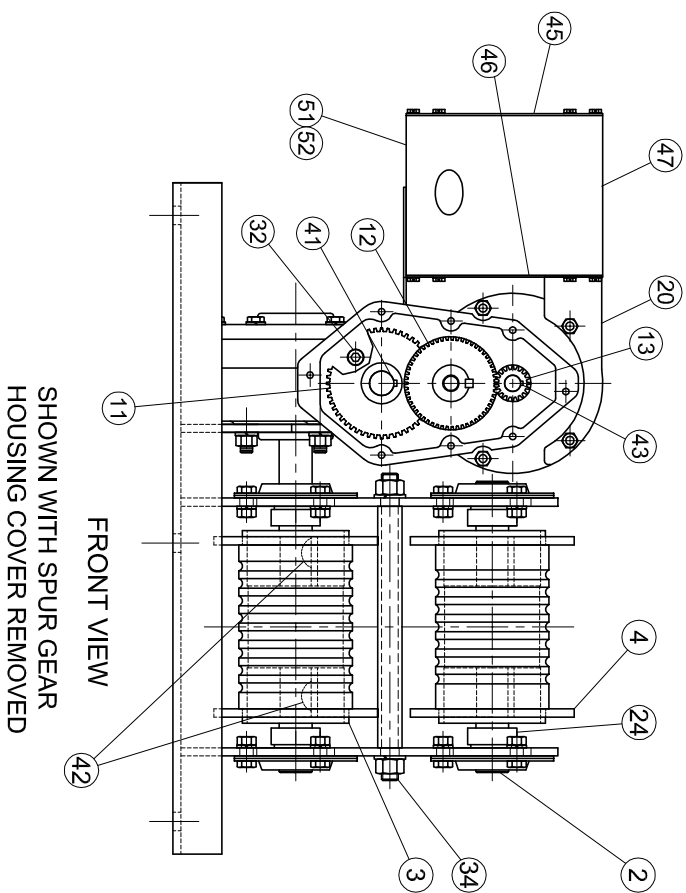
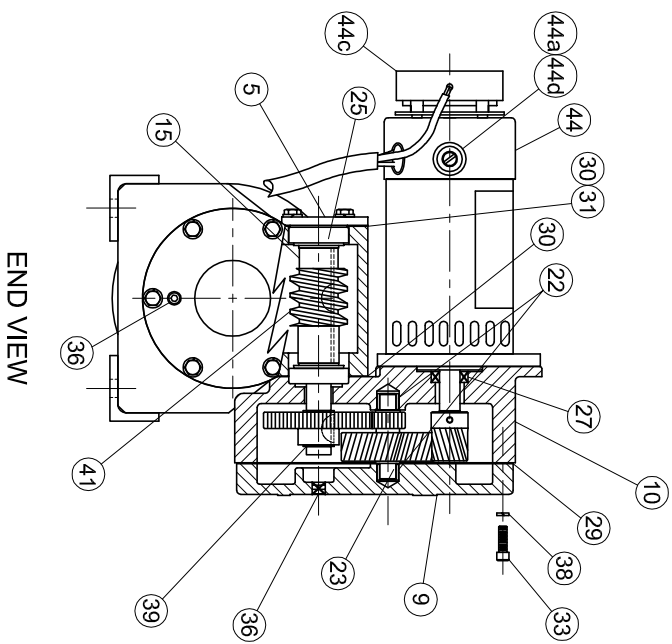
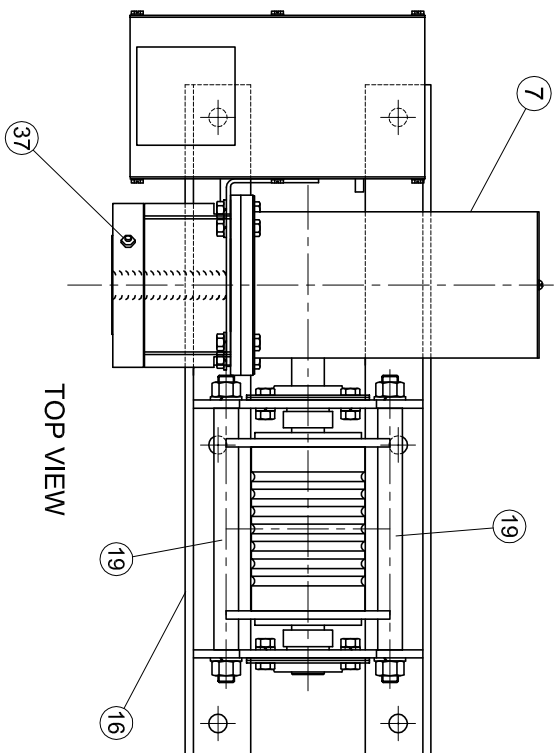
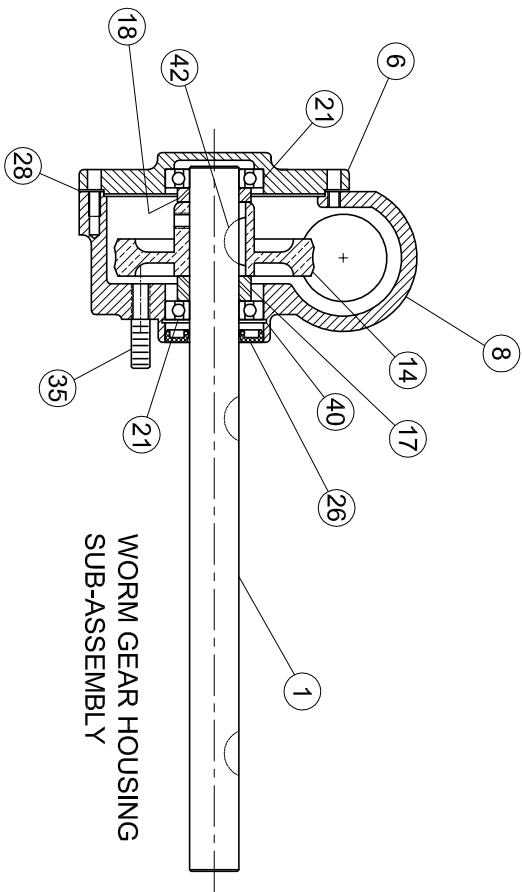

POWER CORD
P/N 548030 (REF)

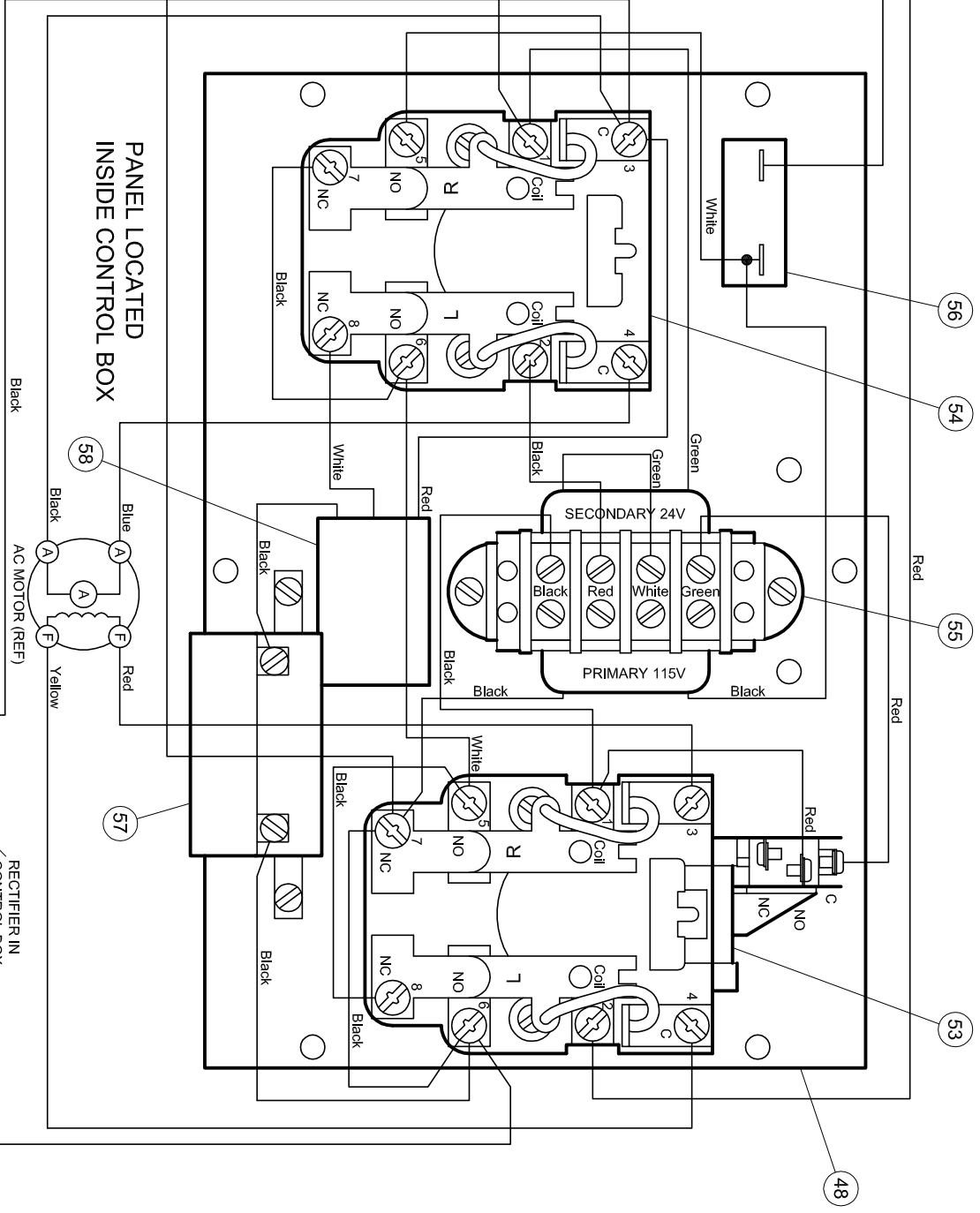

PANEL LOCATED
INSIDE CONTROL BOX

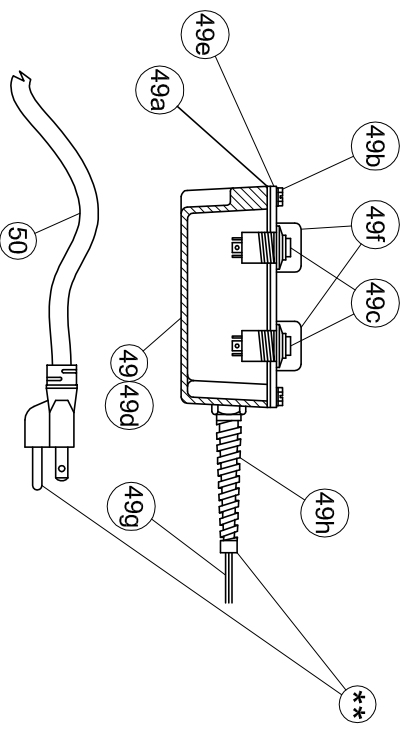

SWITCH CORD P/N 541020
CONNECT WIRES TO TERMINAL
STRIP AT CORRESPONDING
COLOR MARK

