

HY1D Parts List

COMMON FASTENERS AND OTHER ITEMS NOT SHOWN HERE ARE AVAILABLE THROUGH MY-TE PARTS DEPT OR YOUR MY-TE DEALER.

ITEM	QTY	PART No.	DESCRIPTION
1	1	052531	Main Shaft, Long w/o Clutch
2	1	068140	Drum Assy, Long Cast
3	1	081510	Cap, Worm Gear Hsg
4	1	082011	Cover, WGH Closed
5	1	088110	Housing, Worm Gear, w/Studs
6	1	113010	Worm
7	1	113030	Worm Gear, Bronze-No Clutch
8	1	121270	Guard, Motor Coupling - HY3D
9	1	148170	Frame Assy, Standard Long
10	1	148360	Tensioner Bar Assy / Hdw 100A
11	1	171280	Spacer, Thick Main Shaft
12	1	171310	Spacer, Thin Main Shaft
13	2	211010	Bearing, Main Shaft
14	2	211020	Stamping, Flange Bearing
15	1	211030	Bearing, Flangette & Collar
16	2	211040	Bearing, Worm Shaft - Cone
17	2	211050	Bearing, Worm Shaft - Cup
18	1	241010	Oil Seal, Main Shaft - Standard - 1 x 2
19	1	241050	Oil Seal, Worm Shaft - .75 x 1.50 x .25 HY3D
20	1	241510	Gasket, Worm Gear Housing
21	2	241530	Gasket, Worm Gear Housing Cap - 1/32

ITEM	QTY	PART No.	DESCRIPTION
22	2	241540	Gasket, Worm Gear Housing Cap - .010
23	3	282770	Set Screw, Cable Drum $\frac{5}{16}$ "-18 x 1/2 SSS Knurl Point
24	3	286250	Oil Plug, 1/8 NPT
25	1	321530	Snap Ring, Worm Gear Housing -2"
26	2	351020	Woodruff Key, Worm Shaft #607 - $\frac{3}{16}$ x 7/8
27	3	351030	Woodruff Key Main Shaft #1008 - $\frac{5}{16}$ x 1
28	1	461011	Hydraulic Motor, 2.8 Cu. In - 2 Bolt
29	1	461020	Bracket, Motor mounting
30	1	058550	Flex Coupling, for Hydraulic Motor
	.125 Gal.	641510	Worm Gear Oil

ITEM	QTY	PART No.	DESCRIPTION
	1	621020	Decal-Oil Level
	1	621250	Decal-Drum Warning
	1	621260	Decal-Safety 3 x 3
	1	621270	Decal-Capacity & SN
	1	621290	Decal-Made in America
		248022	Seal & Gasket Kit-New Cover

HY1D Parts Drawing

P/N 744011

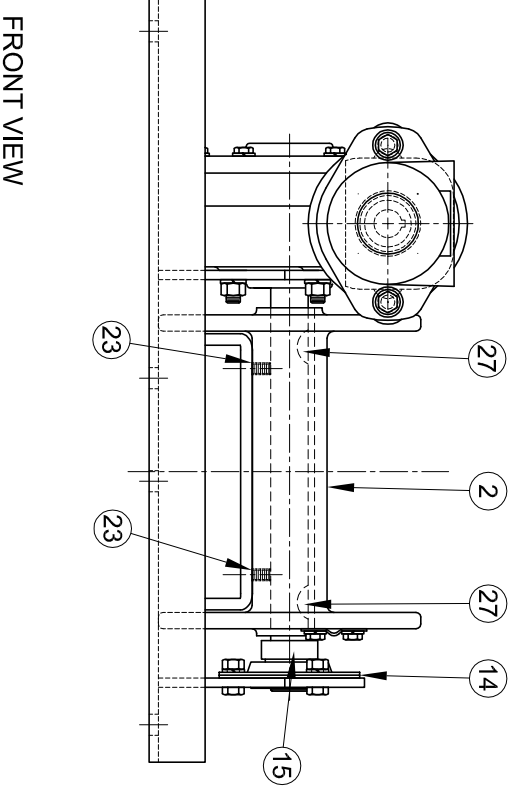
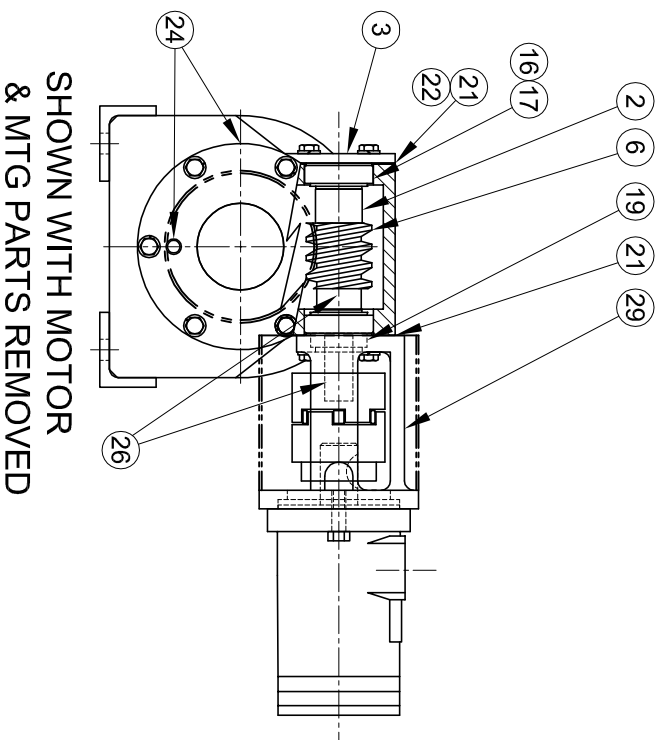
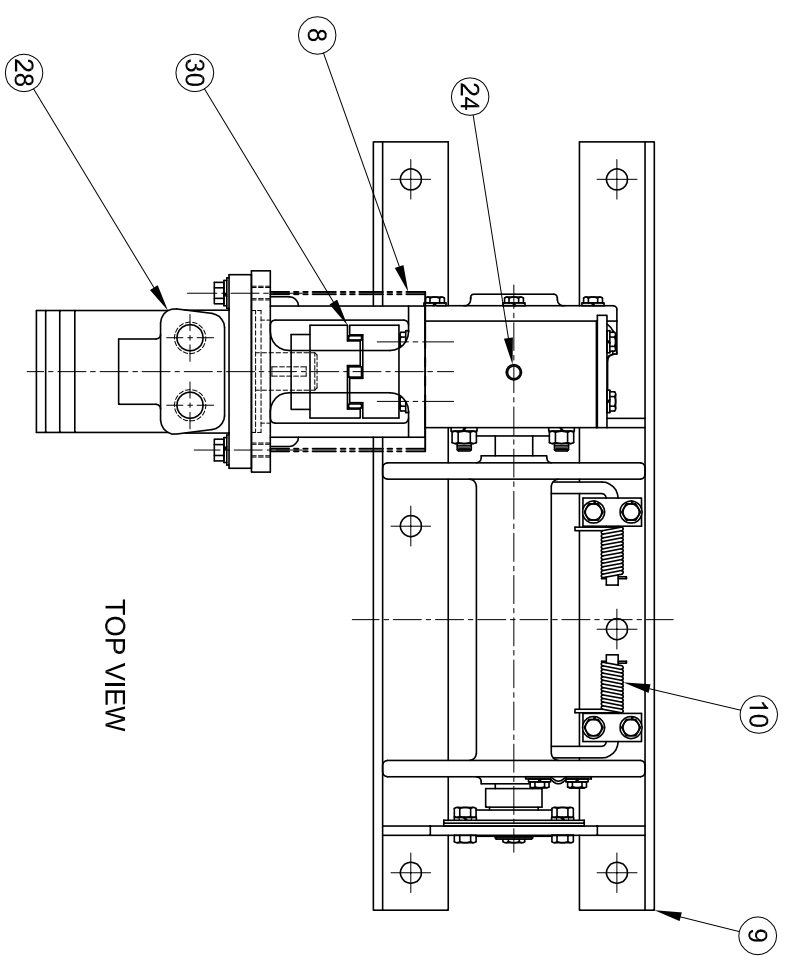
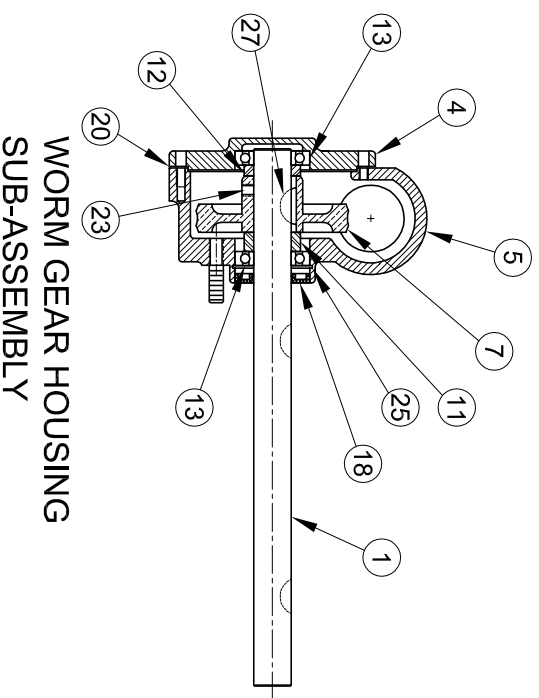

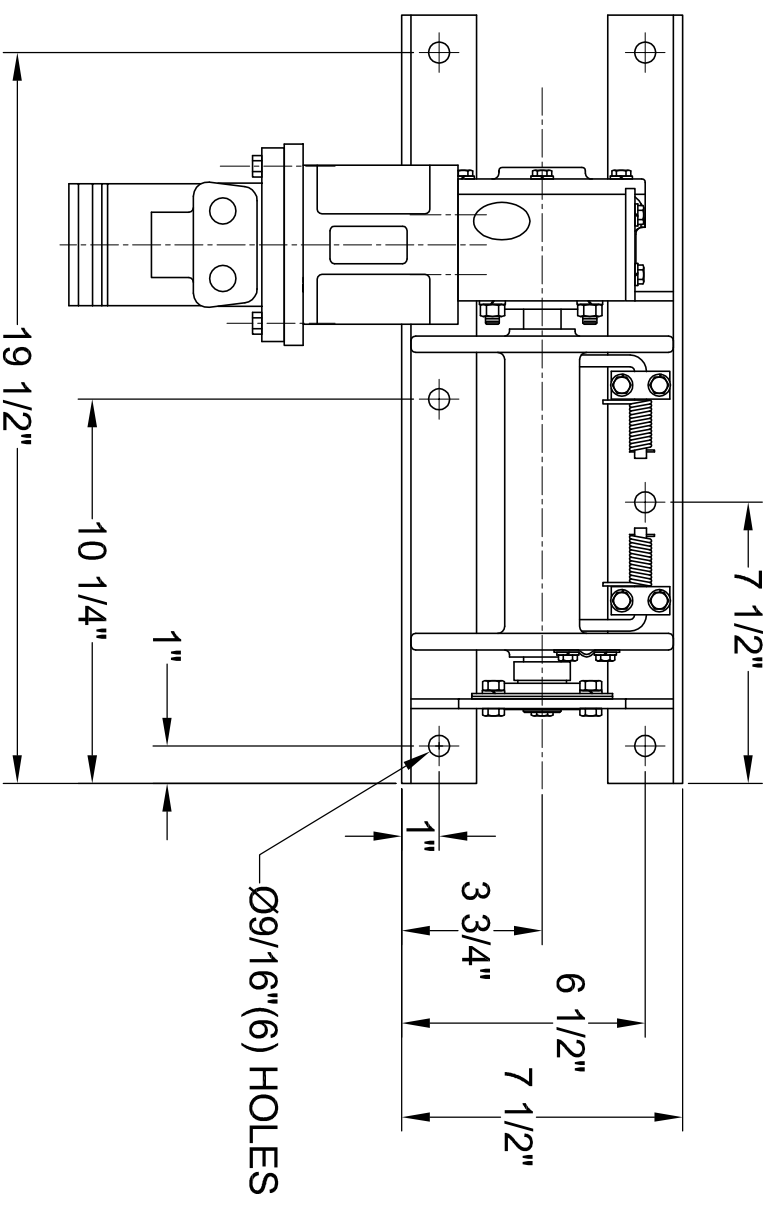

TOP VIEW

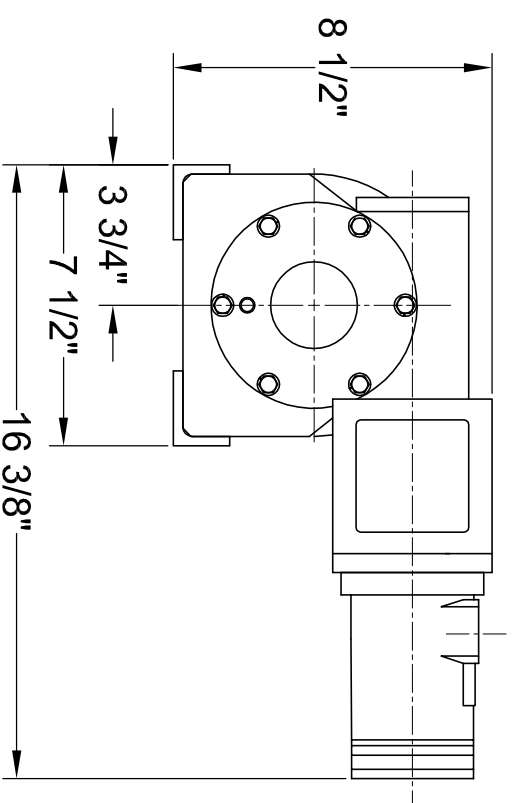

SIDE VIEW

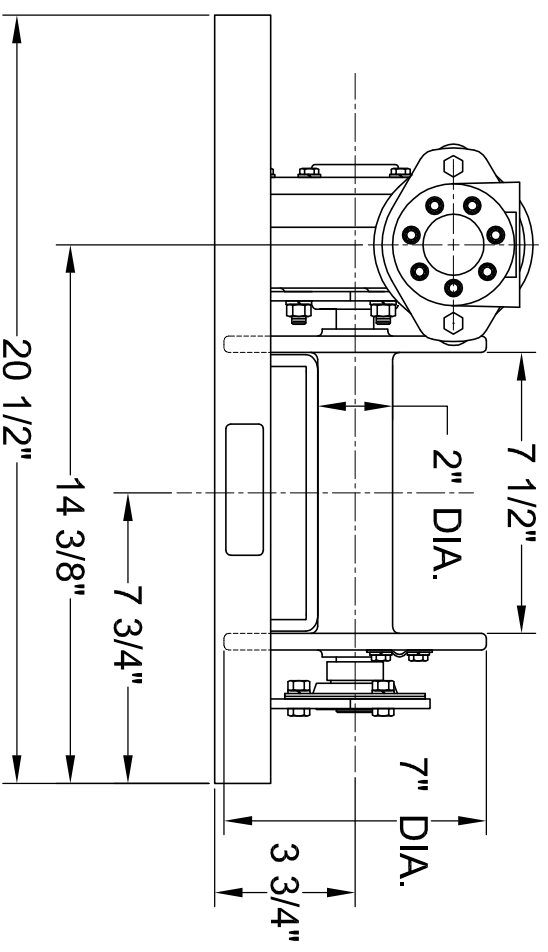

FRONT VIEW